



# SJE HiTempMaster™ Pump Switch Installation Instructions

1052390D 01/20

Mechanically-activated, wide-angle pump switches that provide automatic control of pumps in sump applications up to 200°F (93°C).

The SJE HiTempMaster™ pump switch consists of a float housing with a twin wall design. The switch is not sensitive to rotation or turbulence, allowing it to be used in both calm and turbulent applications.

## SJE HITEMP MASTER™



### Mechanically activated pump and control switch for:

- Water
- Sewage applications

Tether Length (inches)	<b>3.5 min</b>	<b>6</b>	<b>9</b>	<b>12</b>	<b>15</b>	<b>18</b>
Pumping Range (inches)	<b>8</b>	<b>12</b>	<b>17</b>	<b>23</b>	<b>30</b>	<b>36</b>

NOTE: Pumping range listed above is a general guide. Actual pumping range will increase slightly based on the temperature of the water being controlled. Watch several cycles of operation to assure that the pumping range is accurate for your installation.

### PREVENTATIVE MAINTENANCE

- Periodically inspect the product. Check that the cable has not become worn or that the housing has not been damaged so as to impair the protection of the product. Replace the product immediately if any damage is found or suspected.
- Periodically check to see that the float is free to move and operate the switch.
- Use only SJE Rhombus® replacement parts.

## SJE RHOMBUS® FIVE-YEAR LIMITED WARRANTY

Five-Year Limited Warranty.  
For complete terms and conditions, please visit [www.sjerrhombus.com](http://www.sjerrhombus.com).

### NOTICE!

Products returned must be cleaned, sanitized, or decontaminated as necessary prior to shipment to ensure that employees will not be exposed to health hazards in handling said material. All applicable laws and regulations shall apply.

**⚠ WARNING****ELECTRICAL SHOCK HAZARD**

Disconnect power before installing or servicing this product. A qualified service person must install and service this product according to applicable electrical and plumbing codes.

**⚠ WARNING****EXPLOSION OR FIRE HAZARD**

Do not use with flammable liquids. Install in accordance with ANSI/NFPA 70. Suitable for usage with intrinsically safe circuit extensions as defined by UL 698A.

Failure to follow these precautions could result in serious injury or death. Replace product immediately if switch cable becomes damaged or severed. Keep these instructions with warranty after installation. This product must be installed in accordance with National Electric Code, ANSI/NFPA 70 so as to prevent moisture from entering or accumulating within boxes, conduit bodies, fittings, float housing, or cable.

**For detailed specifications on this product, or for the complete line of SJE Rhombus® panel, alarm, and switch products, visit our web-site at [www.sjrhombus.com](http://www.sjrhombus.com).**

**MOUNTING THE SWITCH**

**⚠ WARNING!** The installation site may be HOT. Assure that the installation site is cool to the touch prior to installing to avoid being burned.

- Determine the required cord tether length according to product specifications on the front page and as shown in **Figure A**.
- Refer to **Figure B**. A) Place clamp onto cord. B) Place the clamp onto threaded stud. C) Place the locking nut onto threaded stud and tighten. D) Thread band of hose clamp through slots of mounting clip.
- Locate clamp assembly at desired activation level and secure the hose clamp to the discharge pipe as shown in **Figure B**.  
**Note:** Do not install cord under hose clamp.
- Tighten the hose clamp using screwdriver. Over tightening may result in damage to the clamp components. Make sure the float cable is not allowed to touch the excess hose clamp band during operation.
- Follow direct wire or piggy-back plug instructions for further installation.

**Note:** All hose clamp components are made of 18-8 stainless steel material. See your SJE Rhombus® supplier for replacements.

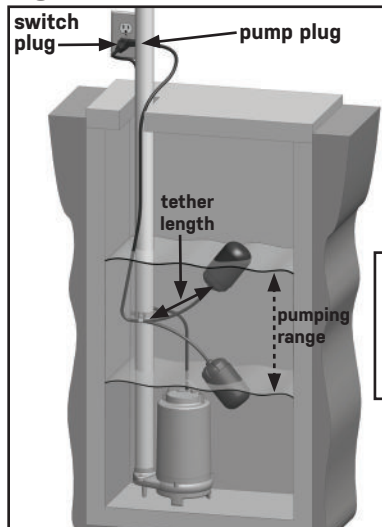
**Figure A**

*Due to weight of cable, pumping range above horizontal is NOT equal to pumping range below horizontal. Use values published on front page as a guide. Pumping ranges are based on testing in non-turbulent conditions. Range may vary due to water temperature and cord shape. Note: As the tether length increases, so does the variance of the pumping range.*

**PIGGY-BACK PLUG INSTALL**

- Electrical outlet must not be located in pump chamber.
  - Electrical outlet voltage, piggy-back plug voltage, and pump voltage must match.
- Follow steps 1 through 4 of "Mounting The Switch."
  - Insert switch's piggy-back plug into outlet as shown in Figure A.
  - Plug pump into piggy-back plug as shown in Figure A.
  - Check installation. Allow system to cycle to insure proper operation.

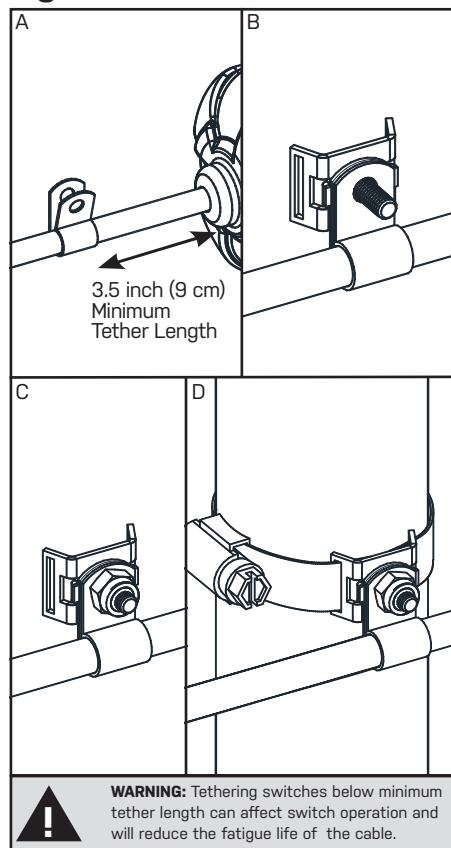
**Figure B**

**⚠ WARNING:** Tethering switches below minimum tether length can affect switch operation and will reduce the fatigue life of the cable.

**DIRECT WIRE INSTALL**

- Follow steps 1 through 4 of "Mounting The Switch."
- Wire switch as shown in **Figure C**.
- Check installation. Allow system to cycle to insure proper operation.

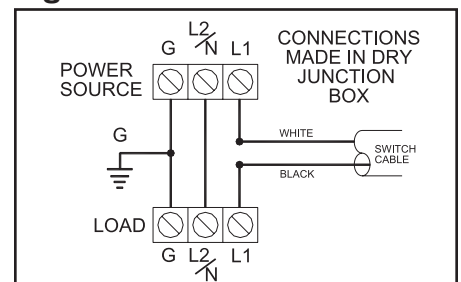
**Figure C****⚠ WARNING**

In 230 VAC installations, one side of the line going to the load is always **HOT**. This condition exists if the switch is on or off. Install double pole disconnect on all 230 VAC circuits.

Ensure cable connections are performed in a **dry** junction box or other watertight seal that seals both conductors and cable jacket. Failure to do so could result in electrical shock hazard and/or water traveling down cable and entering the switch. Failure to guard against this may affect switch performance.



Technical Support: +1 800-746-6287  
techsupport@sjrhombus.com

[www.sjrhombus.com](http://www.sjrhombus.com)

Technical Support Hours: Monday - Friday, 7 A.M. to 6 P.M. Central Time

PN 1052390D 01/20  
© 2020 SJE, Inc. All Rights Reserved.  
SJE RHOMBUS is a trademark of SJE, Inc.