

# PS PATROL® System

**Provides convenient wiring connection and system monitoring for pump station applications.**

The PS Patrol® system features a built-in high water alarm and provides a convenient location to connect all wiring required for a pumping station installation. The PS Patrol® system employs a receptacle to accept a 120 VAC pump and piggy-back style pump switch.

The sleek, angled design of the clear enclosure includes a **removable cover** for easy access for field wiring. All internal components are sealed within the cover for protection from the elements. The **red LED illuminates the cover** in an alarm condition for easy 360° visual identification. Available with or without 32" mounting post.



Shown with Mounting Post  
U.S. Patent Nos. D 780,703 and 9,472,932

## STANDARD FEATURES

- Controller meets Type 3R watertight standards and is designed for outdoor use
- Built-in high water alarm
- Removable cover provides greater access for field wiring and service
- Controller can be purchased with standard 5" square plastic post or can be mounted on 4" schedule 40/80 PVC pipe or conduit (customer supplied)
- Automatic alarm reset, horn silence and alarm test
- 360° visual alarm; audible alarm
- Red LED illuminates cover in alarm condition
- Green Power On light
- Auxiliary alarm contacts included for easy attachment of remote alarm
- Receptacle for easy connection of pump and piggy-back pump switch
- Cord seal included for sealing switches and pump cable
- Electrical potting cavity provides easy reliable method to seal power cables. (User to provide duct seal)
- CSA Certified
- Five-year limited warranty



## OPTIONS

- Mercury or mechanical pump switches
- Various cord lengths
- Riser assembly adapter
- Dual alarm (2nd alarm input - Yellow LED illuminates cover in alarm condition)
- Elapsed Time Meter (ETM)
- Pump circuit breaker
- Available with or without 32" post

## SPECIFICATIONS

**ALARM VOLTAGE:** 120 VAC

**PUMP VOLTAGE:** 120 VAC

**ENCLOSURE SIZE:**

Controller with post 5" X 5" X 39"  
Controller without post 5" X 5" X 8"

**RECEPTACLE:** 120 VAC - NEMA Type 5-15

**AUXILIARY CONTACTS** 120 VAC

0.5 amps max., 50/60 Hz  
(circuit not supervised)

**ALARM HORN:** 82 decibels at 10 feet

**ALARM FLOAT:** SJE SignalMaster® control switch with mounting clamp

California Prop 65 requires the following:  WARNING Cancer and Reproductive Harm - [www.P65Warnings.ca.gov](http://www.P65Warnings.ca.gov)

**SEE REVERSE SIDE FOR ORDERING INFORMATION.  
SEE PRICE BOOK FOR LIST PRICE.**



**SJE RHOMBUS®**

1-888-DIAL-SJE • 1-218-847-1317

1-218-847-4617 Fax

email: [customer.service@sjeinc.com](mailto:customer.service@sjeinc.com)

[www.sjerrhombus.com](http://www.sjerrhombus.com)

**B.73**

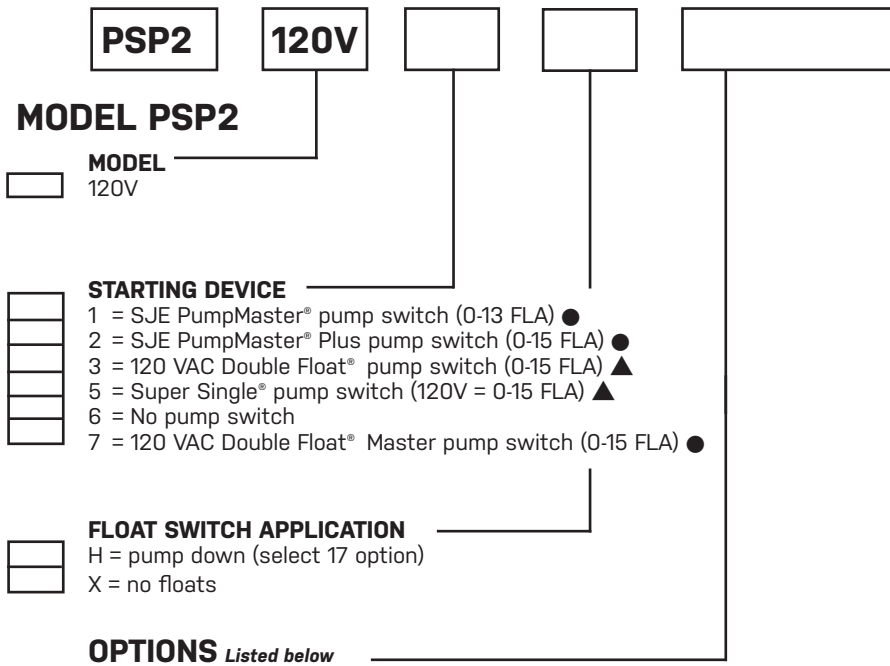

- CODE DESCRIPTION**
- 1J Duo alarm inputs
  - 1V Vertical Reed Switch (*must select 1J*)
  - 8A Elapsed time meter
  - 10X No Mounting Post
  - 15\_P Pump breaker  
*specify 0 or 1 after number 15 followed by letter "P"*  
0 = 15 amp breaker (0-7 FLA)  
1 = 20 amp breaker (7-15 FLA)  
*(Ex. 151P = 20 amp breaker, 7-15 FLA)*

- CODE DESCRIPTION**
- 16A 10' cord in lieu of 20' (*per float*)  
*(Does not apply for Double Float® or Double Float® Master pump switch)*
  - 16B 15' cord in lieu of 20' (*per float*)
  - 16C 30' cord in lieu of 20' (*per float*)
  - 16D 40' cord in lieu of 20' (*per float*)
  - 17A SJE SignalMaster® / pipe clamp (*alarm float*) ●
  - 17J Sensor Float® / pipe clamp (*alarm float*) ▲
  - 22F PSP Assembly Kit

● Mechanically-activated    ▲ Mercury-activated

Part Number	Model Number	Description	FLA	Ship Weight
1022728	PSP2120V6H17A	PSP2 120V, no pump switch, 20' SJE SignalMaster®, with mounting post	0-15	13 lbs.
1019021	PSP2120V6H151P17J	PSP2 120V, no pump switch, 20' Sensor Float®, 20A circuit breaker, with mounting post	7-15	13 lbs.
1022575	PSP2120V6H8A17A	PSP2 120V, ETM, 20' SJE SignalMaster®, with mounting post	0-15	14 lbs.
1022577	PSP2120V6H1JV8A17A	PSP2 120V, Duo alarm, ETM, 20' SJE SignalMaster® & VRS, with mounting post	0-15	15 lbs.
1018434	PSP2AB6H16B17A	PSP2 120V, no alarm, no pump switch; remote TAAB, 15' SJE SignalMaster®, with mounting post	0-15	16 lbs.
1011551	Assembly Kit	Riser Extension Coupling and Washers	n/a	10 lbs.

**Call or fax your order!**  
**1-888-DIAL-SJE (1-888-342-5753) • Fax 218-847-4617**

*Product offering and pricing are subject to change without notice.  
 Please visit [www.sjrhombus.com](http://www.sjrhombus.com) for the most current information.*