

# SJE RHOMBUS<sup>®</sup>

## Control Switch Installation Instructions

SJE-Rhombus<sup>®</sup> narrow-angle control switches accurately monitor liquid levels in water and sewage applications. These switches are designed to activate pump control panels and alarms.

### SJE SIGNALMASTER<sup>®</sup>



- Mechanically-activated.
- Control differential of 1.5 inches above or below horizontal.
- Not sensitive to rotation.
- Mounting options: mounting clamp or cable weight.

### SJE SIGNALMASTER<sup>®</sup> SPDT



- Mechanically-activated.
- Control differential of 1.5 inches above or below horizontal.
- Not sensitive to rotation.
- Mounting options: mounting clamp or cable weight.

### SENSOR FLOAT<sup>®</sup>



- Mercury-activated.
- Suitable for use with an intrinsically safe circuit.\*\*
- Not sensitive to rotation.
- Mounting options: mounting clamp, internal or cable weight.

\*\*Contact SJE-Rhombus for specific intrinsically safe applications.

### SENSOR FLOAT<sup>®</sup> MINI



- Mercury-activated.
- Narrow angle float switch in a small float housing.
- Suitable for use with an intrinsically safe circuit.\*\*
- Not sensitive to rotation.
- Mounting options: mounting clamp or cable weight.

\*\*Contact SJE-Rhombus for specific intrinsically safe applications.

#### PREVENTATIVE MAINTENANCE

- Periodically inspect the product. Check that the cable has not become worn or that the housing has not been damaged so as to impair the protection of the product. Replace the product immediately if any damage is found or suspected.
- Periodically check to see that the float is free to move and operate the switch.
- Use only SJE-Rhombus<sup>®</sup> replacement parts.
- The Sensor Float<sup>®</sup> and Sensor Float<sup>®</sup> Mini control switches contain mercury and MUST be recycled or disposed of according to local, state, and federal codes.

#### SJE-RHOMBUS<sup>®</sup> FIVE-YEAR LIMITED WARRANTY

Five-Year Limited Warranty. For complete terms and conditions, please visit [www.sjerrhombus.com](http://www.sjerrhombus.com).

#### NOTICE!

Products returned must be cleaned, sanitized, or decontaminated as necessary prior to shipment to ensure that employees will not be exposed to health hazards in handling said material. All applicable laws and regulations shall apply.

**⚠ WARNING****ELECTRICAL SHOCK HAZARD**

Disconnect power before installing or servicing this product. A qualified service person must install and service this product according to applicable electrical and plumbing codes.

**⚠ WARNING****EXPLOSION OR FIRE HAZARD**

Do not use with flammable liquids. Install in accordance with ANSI/NFPA 70. Suitable for usage with intrinsically safe circuit extensions as defined by UL 698A.

Failure to follow these precautions could result in serious injury or death. Replace product immediately if switch cable becomes damaged or severed. Keep these instructions with warranty after installation. This product must be installed in accordance with National Electric Code, ANSI/NFPA 70 so as to prevent moisture from entering or accumulating within boxes, conduit bodies, fittings, float housing, or cable.

*For detailed specifications on this product, or for the complete line of SJE-Rhombus® panel, alarm, and switch products, visit our web-site at [www.sjrhombus.com](http://www.sjrhombus.com).*

**MOUNTING THE SWITCH**

**WARNING:** Do not install switch in direct line of incoming liquid.

1. Place the cord into the clamp as shown in Figure C.
2. Locate clamp at desired activation level and secure the clamp to the discharge pipe as shown in Figures A and B. **Note:** Do not install cord under hose clamp.
3. Tighten the hose clamp using screwdriver. Over tightening may result in damage to the plastic clamp. Make sure the float cable is not allowed to touch the excess hose clamp band during operation.
4. Wire switch as shown in Figure D.
5. Check installation. Allow system to cycle to insure proper operation.

**Note:** All hose clamp components are made of 18-8 stainless steel material. See your SJE-Rhombus® supplier for replacements.

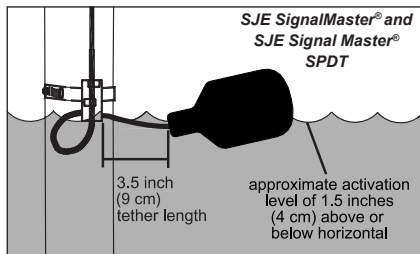
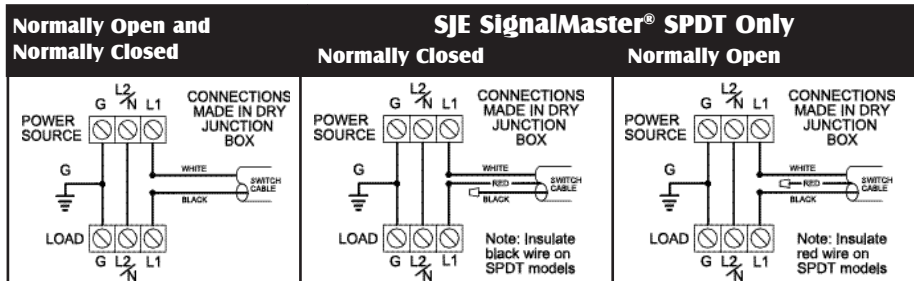
**Figure A****Figure D****⚠ WARNING**

In 230 VAC installations, one side of the line going to the load is always **HOT**. This condition exists if the switch is on or off. Install double pole disconnect on all 230 VAC circuits.

On SPDT Models, insulate unused red or black wires with wire nut. Wire can become electrically hot.

Ensure cable connections are performed in a **dry** junction box or other watertight seal that seals both conductors and cable jacket. Failure to do so could result in electrical shock hazard and/or water traveling down cable and entering the switch. Failure to guard against this may affect switch performance.

**CABLE WEIGHT**

1. Determine desired activation level.
2. Suspend switch and cable weight at desired activation level as shown in Figure E.
3. Wire switch as shown in Figure D.
4. Check installation. Allow system to cycle to insure proper operation.

To adjust cable weight tether length:

1. Release clip.
2. Adjust cable weight to desired position.
3. Lay switch cable in weight channel.
4. Align clip with weight channel and slide towards switch cable as shown in Figure E.
5. Snap clip snugly up to cable, moving clip to tightest possible position.

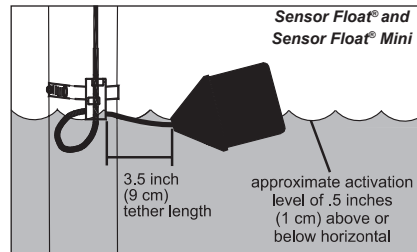
**Figure B****INTERNAL WEIGHT****SENSOR FLOAT® CONTROL SWITCH ONLY**

1. Determine desired activation level as shown in Figures A and B.
2. Suspend switch 7 inches (18 cm) below desired activation level as shown in Figure F. Switch remains partially submerged during the "on" tipping action. Switch can be totally submerged and still continue to operate properly.
3. Wire switch as shown in Figure D.
4. Check installation. Allow system to cycle to insure proper operation.

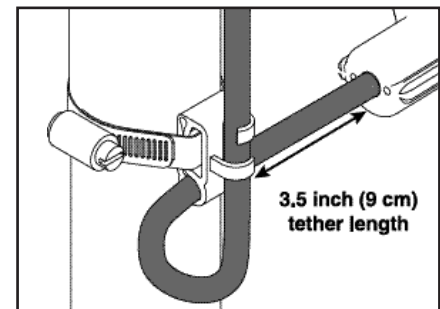
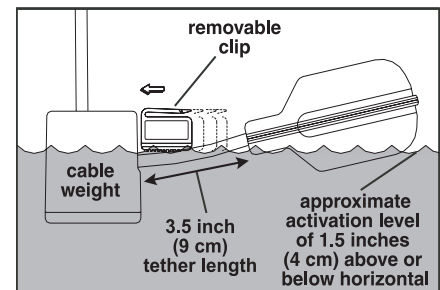
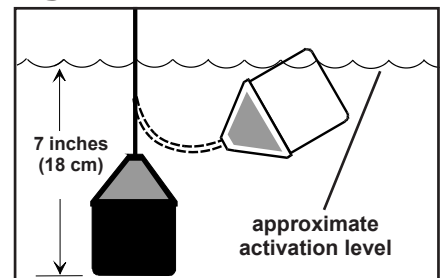
**Figure C****Figure E****Figure F**

22650 County Highway 6 ■ P.O. Box 1708 ■ Detroit Lakes, Minnesota 56502 USA  
 1-888-DIAL-SJE (1-888-342-5753) ■ Phone: 218-847-1317 ■ Fax: 218-847-4617  
[www.sjrhombus.com](http://www.sjrhombus.com) ■ E-mail: [customer.service@sjrhombus.com](mailto:customer.service@sjrhombus.com)