

PS Patrol™ system with 120V Alarm Installation Instructions

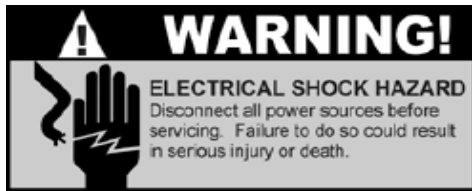

INSTALLING THE PS PATROL™

This control panel must be installed and serviced by a licensed electrician in accordance with the National Electric Code NFPA-70, state and local electrical codes.

1. Determine where the pedestal will be placed.
2. Drill access hole for incoming cords (ie: pump, pump switch, and alarm float).
NOTE: Use conduit and connectors as required.

NOTE: Alarm float and pump switch float cables are not direct burial cables and are not intended to be directly buried. Doing so is in direct violation of NEC Code 310.7

Figure A

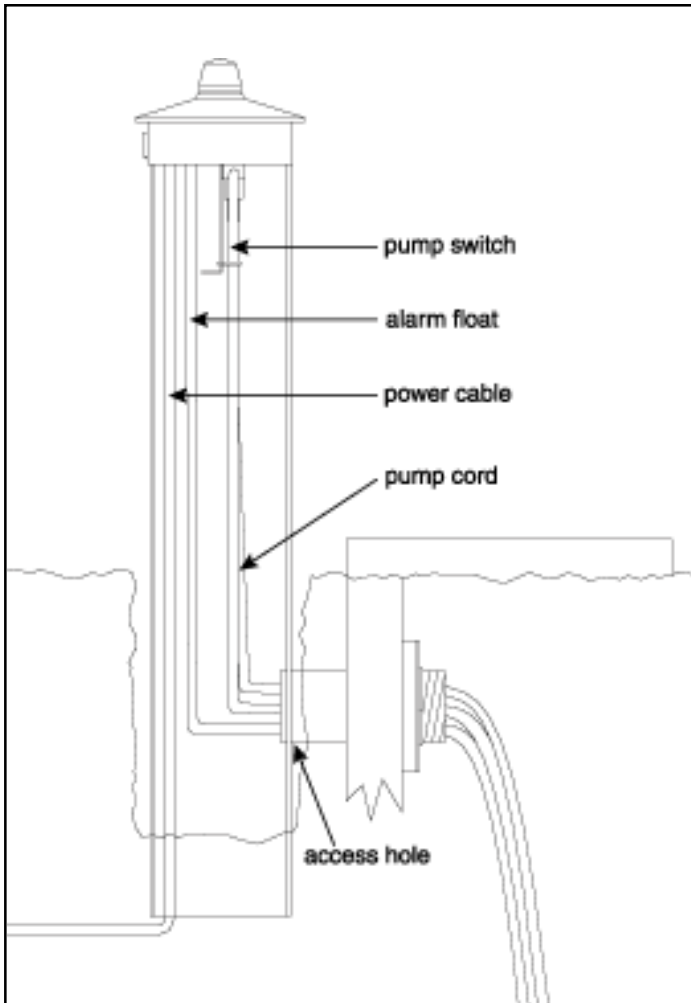

3. Route pump, pump switch, and alarm float cords through access hole as shown in Figure A.
4. Route the incoming power cable as shown in Figure A.
5. Connect alarm float, alarm power, and pump power using provided wire nuts as shown in Figure B.
6. Plug pump switch (if applicable) and pump into receptacle on inner plate as shown in Figure C. Secure the cord with wire tie as shown in Figure C.
7. Place cap on pedestal.
NOTE: Install cover screws as shown in Figure A to prevent tampering.
8. Test PS Patrol™ system (see page 2).
9. Back fill pedestal hole as shown in Figure A.

Figure B

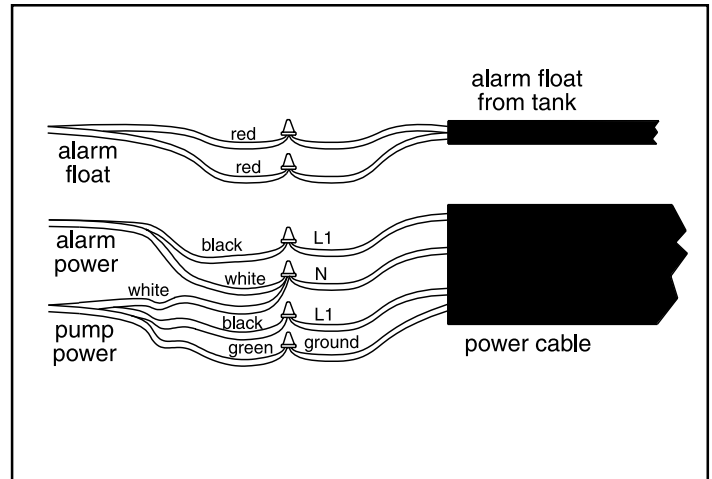
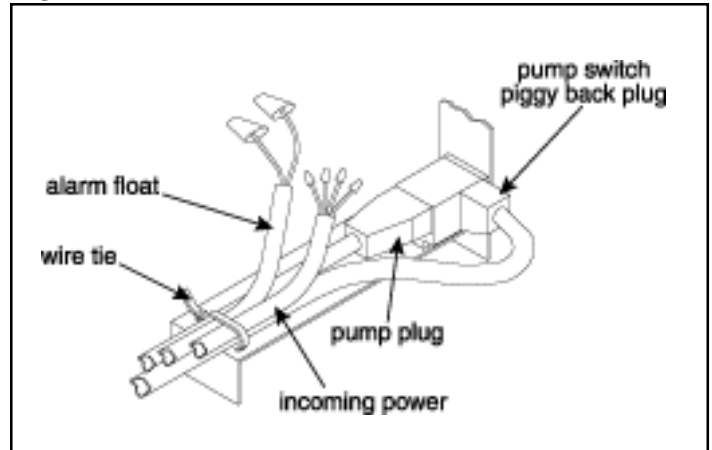

Figure C



Installation Instructions

TESTING THE PS PATROL™

1. Turn on 120 VAC power to system.
2. Move the test/normal/silence switch to the **test** position. The horn should sound and the alarm light will illuminate.
3. Place test/normal/silence switch back to **normal**.
4. Lift alarm float. The horn should sound and the alarm light will illuminate.
5. Move the test/normal/silence switch to the **silence** position. Horn should stop.
6. Lower alarm float and move test/normal/silence switch to the **normal** position.
7. Lift pump switch.
NOTE: Verify there is water in the tank so the pump does not run dry.
8. Pump should run.
9. Lower pump switch.
10. Pump should stop running.

2. Mount float switches at appropriate levels as illustrated in **Figure 3**. Be sure that floats have free range of motion without touching each other or other equipment in the basin.
3. For mounting clamp installation: place the cord into the clamp as shown in **Figure 3**. Locate the clamp at the desired activation level and secure the clamp to the discharge pipe as shown in **Figure 3**.

NOTE: Do not install cord under hose clamp.

4. Tighten the hose clamp using a screwdriver. Over tightening may result in damage to the plastic clamp. Make sure the float cord is not allowed to touch the excess hose clamp band during operation.

NOTE: All hose clamp components are made of 18-8 stainless steel material. See your SJE-Rhombus® supplier for replacements.

INSTALLATION OF FLOATS

CAUTION: If control switch cords are not wired and mounted in the correct order, the pump system will not function properly.

WARNING: Turn off all power before installing floats in pump chamber. Failure to do so could result in serious or fatal electrical shock.

1. Determine your normal operating level, as illustrated in **Figures 1 & 2**.

DETERMINING PUMPING RANGE (IN INCHES)

Super Single® pumping range	tether length	3.5	5	7	9	11	13	15
	pumping range	6.5	7.5	8.5	10	11	12.5	13.5

SJE PumpMaster Plus® pumping range	tether length	3.5	6	10	14	18	22	24
	pumping range	7	10	16	22	28	33	36

Use only as a guide. Pumping ranges are based on testing in non-turbulent conditions. Range may vary due to water temperature and cord shape. **Note:** As the tether length increases, so does the variance of the pumping range.

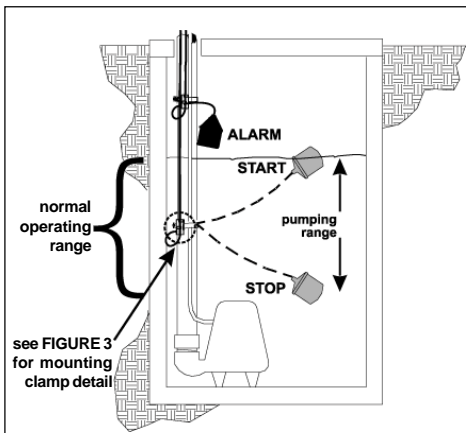

FIGURE 1

Wide angle* float system

*Super Single® or SJE PumpMaster® Plus
(See chart above to determine pumping range)

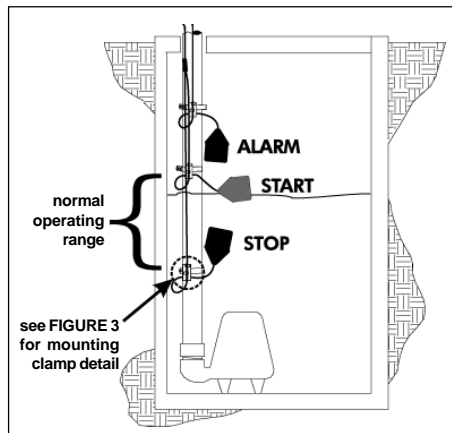

FIGURE 2

SJE Double Float™ system

NOTE: SJE Double Float™ voltage must match pump voltage.

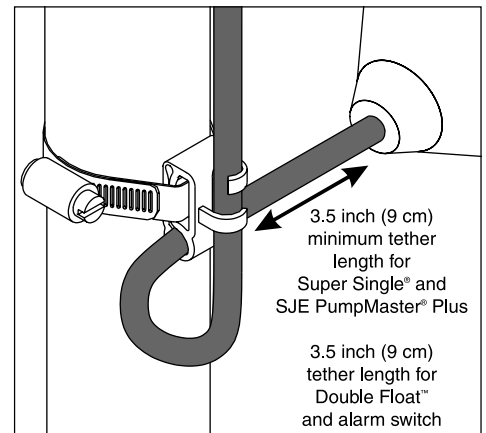

FIGURE 3

Mounting clamp detail

Troubleshooting



Alarm Light and Horn

Moving the test/normal/silence switch to the test position or activating the alarm float should turn on the alarm light and horn.

Float Controls

Check the floats during their entire range of operation. Clean, adjust, or replace damaged floats.

Checking the float resistance

The float resistance can be measured to determine if the float is operating correctly or is defective. Use the following procedure to measure the float resistance.

WARNING: Disconnect incoming power to panel.

1. Isolate the float by disconnecting one or both of the float leads from the float terminals.
2. Place one ohmmeter lead on one of the float wires, and the other ohmmeter lead on the other float wire.
3. Place the ohmmeter dial to read ohms and place on the R X 1 scale. With the float in the "off" position, the scale should read infinity (high resistance). Replace the float if you do not get this reading. With the float in the ON position, the scale should read nearly zero (very low resistance). Replace the float if you do not get this reading.

NOTE: Readings may vary depending on the length of wire and accuracy of the measuring device.

SJE-Rhombus® Three-Year Limited Warranty

SJE-RHOMBUS® warrants to the original consumer that this product shall be free of manufacturing defects for three years after the date of consumer purchase. During that time period and subject to the conditions set forth below, **SJE-RHOMBUS®** will repair or replace, for the original consumer, any component which proves to be defective due to defective materials or workmanship of **SJE-RHOMBUS®**.

ELECTRICAL WIRING AND SERVICING OF THIS PRODUCT MUST BE PERFORMED BY A LICENSED ELECTRICIAN.

THIS WARRANTY DOES NOT APPLY: (A) to damage due to lightning or conditions beyond the control of **SJE-RHOMBUS®**; (B) to defects or malfunctions resulting from failure to properly install, operate or maintain the unit in accordance with printed instructions provided; (C) to failures resulting from abuse, misuse, accident, or negligence; (D) to units which are not installed in accordance with applicable local codes, ordinances, or accepted trade practices, and (E) to units repaired and/or modified without prior authorization from **SJE-RHOMBUS®**.

Some states do not allow limitations on how long an implied warranty lasts, so the above limitation may not apply to you. Some states do not allow the exclusion or limitation of incidental or consequential damages, so the above limitation or exclusion may not apply to you. This warranty gives you specific legal rights, and you may also have other rights which vary from state to state.

TO OBTAIN WARRANTY SERVICE: The consumer shall assume all responsibility and expense for removal, reinstallation, and freight. Any item to be repaired or replaced under this warranty must be returned to **SJE-RHOMBUS®**, or such place as designated by **SJE-RHOMBUS®**.

ANY IMPLIED WARRANTIES OF MERCHANTABILITY OR FITNESS ARE LIMITED TO THE DURATION OF THIS WRITTEN WARRANTY. SJE-RHOMBUS® SHALL NOT, IN ANY MANNER, BE LIABLE FOR ANY INCIDENTAL OR CONSEQUENTIAL DAMAGES AS A RESULT OF A BREACH OF THIS WRITTEN WARRANTY OR ANY IMPLIED WARRANTY.

