

# Innovative Custom Embedded Control Solutions

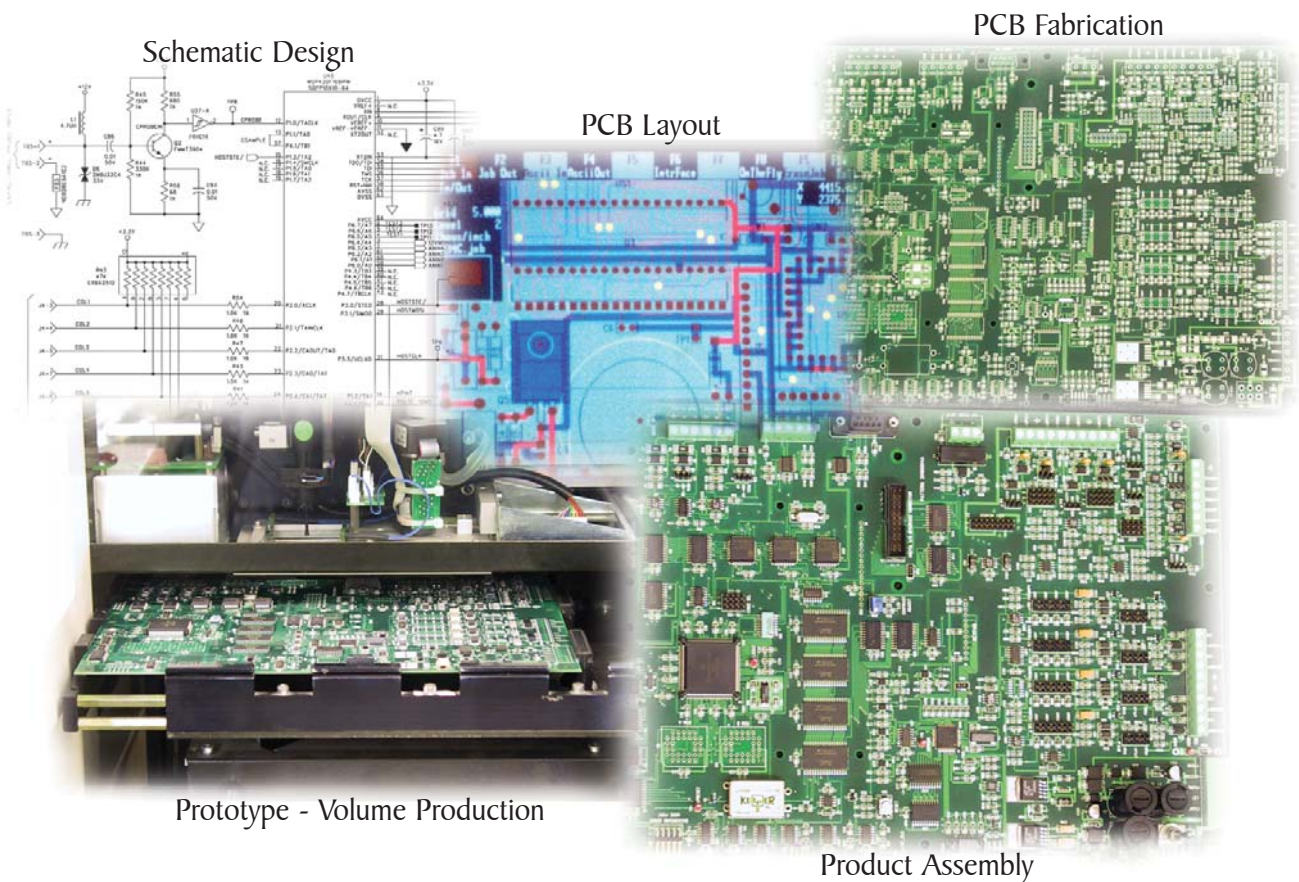

Over 30 Years of Experience in  
Custom Printed Circuit Board Technology

Let us design a custom solution for you!



**TAMARACK  
ENGINEERING**

**SJE-  
Rhombus**  
CONTROLS

[www.sjrhombus.com](http://www.sjrhombus.com)

# Let us design a custom solution for you!

For **30 years**, SJE-Rhombus/Tamarack Engineering has been building a reputation for providing **reliable products and superior customer service**. New product designs endure extensive in-house and field testing before submittal to recognized independent laboratories for safety testing and approval. Each product is constructed of the **highest quality materials** with **expert workmanship** and delivered in **responsive lead-times**. This commitment to quality ensures a **dependable, trouble-free product**.

SJE-Rhombus/Tamarack Engineering guarantees **exceptional customer service** with a knowledgeable team of engineers, technicians and specialists committed to providing **unparalleled support**.

## SERVICES

- Custom Circuit Schematic Design
- Printed Circuit Board Layout
- Firmware/Software Development
- Part Selection & Procurement
- Rapid Prototyping
- Validation Testing
- Volume Production
- Final Product Assembly

## APPLICATIONS

- Industrial Controls
- Speed, Temperature, Motion, Pressure, Position Control
- Embedded Microprocessor/Microcontroller Design
- Man-Machine Interfaces
- Custom Application Software for PC and PDA
- Communications
- Remote Control

Please contact **Jeff Thon** with Tamarack Engineering to learn how we can develop a solution for you!



# TAMARACK ENGINEERING

7950 University Avenue NE, Fridley, MN 55432  
Phone: **763.231.6601** ■ Fax: **763.231.6603**  
Cell: **952-270-3799**  
Email: **JeffT@sjrhombus.com**



22650 Co. Hwy. 6, Detroit Lakes, MN 56501  
Phone: **218-847-1317** ■ Fax: **218-847-4617**  
**www.sjrhombus.com**